

# Sampling and processing marine benthic invertebrates

Operational instruction 009\_07

Issued 10/03/2010

This document is for staff at level 3 capability of the marine macro-invertebrate in the environment monitoring technical development framework.



Document details

## What is this document about?

This document covers the collection, processing and fixing of benthic invertebrate samples collected subtidally and intertidally in transitional and coastal waters. It also includes important safety information for grab sampling and the use and transport of formaldehyde.

Analysis of the processed samples is covered in [008\\_07 Determining numbers and biomass of macroinvertebrates from marine sediments](#). Water Framework Directive sampling is covered in [104\\_10 Sampling macrobenthic invertebrates in WFD Transitional and Coastal Waters](#).



Related documents

## Who does this apply to?

Staff undertaking macrobenthic invertebrate sampling on vessels or on the shore:

- Analysis and Reporting and Sample and Collection staff;
- Marine Monitoring Service (MMS).



Feedback

## Contents

<a href="#">Health and safety</a>	<a href="#">2</a>
<a href="#">Purpose of marine benthic invertebrate sampling</a>	<a href="#">3</a>
<a href="#">Subtidal Sampling</a>	<a href="#">5</a>
<a href="#">Intertidal Sampling</a>	<a href="#">12</a>
<a href="#">Sample processing</a>	<a href="#">18</a>
<a href="#">Appendix 1: Sampling devices</a>	<a href="#">25</a>
<a href="#">Appendix 2: Hopper devices</a>	<a href="#">32</a>
<a href="#">Appendix 3: Subtidal macrofaunal field record</a>	<a href="#">35</a>
<a href="#">Appendix 4: Intertidal macrofaunal field record</a>	<a href="#">37</a>
<a href="#">Appendix 5: Macrobenthic invertebrate sampling CSV: Competency Audit</a>	<a href="#">39</a>
<a href="#">Appendix 6: Macrobenthic invertebrate sampling on foot: Competency Audit</a>	<a href="#">41</a>
<a href="#">Related documents</a>	<a href="#">43</a>

Contact for queries

Sarah Peaty

## Health and safety

---

### Personal health and safety requirements

To engage in the collection, processing and fixing of benthic invertebrate samples you must:

- be fit for the task, have adequate training and experience, or be a new member of staff under the supervision of suitably qualified and experienced staff;
- have training in fieldwork and in the survey techniques referred to;
- equip yourself with personal protective equipment (PPE);
- be fully aware of the required health and safety control measures, as detailed in the following generic risk assessments (GRA):
- [06\\_10 Boatwork](#);
- [725\\_06 Fieldwork](#);
- [189\\_06 GRA Grabbing, coring and trawling](#);
- [426\\_05 GRA Working in or near water](#);
- [193\\_06 GRA Intertidal soft sediment work](#).

Further health and safety information is available in [Related documents](#) and the following sections:

- [Important safety information for subtidal benthic sampling](#);
  - [Important safety information for intertidal sampling](#);
  - [Important safety information for using formaldehyde](#).
-

## Purpose of marine benthic invertebrate sampling

---

### Contents

This chapter includes the following topics:

Topic	See page
<a href="#">Purpose of marine benthic invertebrate sampling</a>	<a href="#">3</a>
<a href="#">Sampling design</a>	<a href="#">4</a>

---

## Purpose of marine benthic invertebrate sampling

---

### Why macrofauna?

Most marine macrofauna live in the sediment, and they:

- are sedentary;
- feed upon sediment-dwelling organisms or the sediment itself;
- are relatively long-lived (more than one year).

Consequently they provide a suitable group to target for biomonitoring studies and are a measure of the integration of contaminant effects over time. Biological information, combined with data from physical and chemical analyses, provides important indications as to the quality of marine and estuarine environments.

---

### Studies

We collect marine benthic invertebrate samples for a number of purposes:

- **WFD** - benthic invertebrates are one of five biological quality elements required for ecological status assessments as part of a wider water-body assessment;
  - **CSEMP (Clean Seas Environmental Monitoring Programme)** - is a national programme that meets the UK government (Oslo and Paris) OSPAR monitoring commitments under the OSPAR Joint Assessment and Monitoring Programme for the North-east Atlantic;
  - **Note:** This programme was formally known as NMMP (National Marine Monitoring Programme).
  - **Regional/Area Investigative Monitoring** - surveys investigating particular problem areas;
  - **Research and development** - surveys for research and development purposes.
- 

### When to sample

Collect samples during Spring (1 February – 31 May).

CSEMP sampling should take place within +/- 3 weeks of the original sampling date in 1999 or 2000. If sampling is undertaken during May or June then +/- 2 weeks is recommended, as per the CSEMP [green book](#).

## Sampling design

---

Sampling design for WFD or CSEMP is already dictated. However, investigative and R&D monitoring must consider the following points. A well thought out survey plan is essential; the number of replicate samples at each site will depend on the objectives and requirements of the survey. Due to the heterogeneity of marine and estuarine communities, a single sample will not provide adequate information to describe the communities. So multi-replicate sampling is necessary ([Kramer et al, 1994](#)). Such a sampling strategy must take into account the natural spatial variability and have the power to detect significant changes.

The number of replicates required will depend on the level of precision the study requires and the efficiency of the sampling device you use, but for temporal trends we recommend five replicates. Subtidal grabs used in benthic monitoring work have a standard specification of an effective sampling area of 0.1 m<sup>2</sup>. Employ a consistent sample size across all monitoring drivers to ensure the resulting data is usable for more than its primary purpose.

---

## Sampling considerations

---

Employ quantitative techniques to enable direct comparisons between sites and take samples from reference sites for comparison. Ensure your methods are consistent, so that you can attribute any differences you observe to environmental factors, rather than to variation in your sampling procedures.

Anyone involved in collecting and processing marine benthic samples must have received training/instruction from a suitably experienced person. Training must cover the safe use of all equipment and the chemicals that we use as well as the methods necessary to ensure we obtain quality data.

---

## Subtidal Sampling

---

### Contents

This chapter includes the following topics:

Topic	See page
<a href="#">Sampling devices (subtidal)</a>	<a href="#">5</a>
<a href="#">Subtidal sampling devices</a>	<a href="#">6</a>
<a href="#">Subtidal sample collection competency</a>	<a href="#">6</a>
<a href="#">Subtidal sample collection</a>	<a href="#">6</a>
<a href="#">Important safety information for subtidal benthic sampling</a>	<a href="#">10</a>

---

## Sampling devices (subtidal)

---

### Device types

Traditionally survey vessels deploy grabs and corers, taking sediment of a known area to collect quantitative, subtidal benthic samples from coastal and estuarine waters. The material collected must be relatively undisturbed. Corers are the preferred sampling device when an undisturbed sample is essential. It is impossible to avoid some sample distortion that is associated with the biting mechanism of a grab ([see Kingston, 1988](#)).

---

### Sample depth

The weight of a sampler determines the depth of the sample it obtains. Due to the variety of substrata you may encounter, adding and removing weights from the sampling device is an easy way to facilitate optimum penetration. In practice few grabs dig deeper than 10 cm ([Eleftheriou and Holme, 1984](#)), although this is not necessarily critical as 90% of benthic macrofauna inhabit the top 5 cm of the sediment ([Ankar, 1977](#)).

---

### Choosing a sampling device

The choice of sampling device must satisfy a number of criteria:

- the ability to sample efficiently in different sediments;
- ease of shipboard handling;
- and whether the samples provide adequate information to answer the scientific questions asked.

The Environment Agency (and our predecessor's) standard sampling device for marine and estuarine work is a 0.1 m<sup>2</sup> day grab, which is reliable and simple to use. Consistent use of a standard sampling size and device means data collected for one survey purpose can be used again in future studies using the same standards.

---

## Subtidal sampling devices

---

The following subtidal benthic sampling gear is described in detail in [Appendix 1: Sampling devices](#).

- day grab - 0.1 m<sup>2</sup>;
  - Van Veen grab - 0.1 m<sup>2</sup>, 0.05 m<sup>2</sup>, 0.025 m<sup>2</sup>;
  - box corer.
- 

## Subtidal sample collection competency

---

### Who carries out sample collection?

Subtidal sample collection must be carried out by a competent person, or under the supervision of a competent person. See [Appendix 5](#) for a checklist to audit competency and quality of sample collection. Gain competency through the following process:

Stage	Description
1	View the Marine ecology sampling CD and complete the on-line assessment.
2	Read and understand <a href="#">189_06 GRA: Grabbing, coring and trawling</a> and this instruction on marine benthic invertebrate sampling.
3	Observe a sample collection (from collection to fixing of samples) by competent officers.
4	Carry out a sample collection (from collection to fixing of samples) under the supervision of a competent officer at least <b>four</b> times.
5	You achieve competency when your team leader acknowledges you have developed sufficient skill. Your team leader must keep a record of competency. You must keep a copy as part of your training record.

---

## Collecting subtidal samples

---

### Choosing a site

Locate the position of each sampling site using on-board navigational aids. Record the datum.

**Note:** Applying an incorrect datum (such as OSGB instead of WGS84) to a set of co-ordinates can result in a positional error as great as 110 m.

---

### Operating the sampling device

A subtidal sampling device is a heavy piece of equipment requiring a boat equipped with a winch and gantry for deployment and retrieval. Observe the following rules when operating the device:

- **only crew members who are specifically trained in winch operation must use the winch.** While the winch is operating, all workers must be aware and stay clear of moving winch cables in case of sudden snatching of the cables;
- two operators must work in a co-ordinated and controlled manner when setting and emptying sampling devices, keeping hands and fingers clear of the sampling jaws (when grabbing) and ensuring fingers are kept clear of moving cables and levers;
- position sampling devices securely on a suitable stand when in use, or on the deck when not required;
- when not in use, secure or immobilise any moving parts that represent a potential hazard;
- **Example:** When a day grab is not in use, it must be left in the fired position, so there is no danger of it suddenly closing.

### Lowering and raising the sampling device

Use the following procedure when lowering and raising the sampling device:

Step	Action
1	<p>Deploy and retrieve the sampling device using the winch, directing the warp through the hydraulic gantry.</p> <p><b>Note:</b> The sampling device (for instance the grab) may swing as a result of the vessel moving. To avoid unnecessary swinging, <b>do not use the sampling device in conditions above Beaufort scale 3</b>, unless the sea state is sheltered (such as in small estuaries).</p>
2	<p>Two workers wearing lifejackets, hard hats and steel toe-cap boots manually guide the benthic sampling gear to the stern.</p> <p>Use a dampner, which is a frame fixed around the warp to limit its field of movement, to reduce swinging. You must use dampners if they are available on a vessel.</p> <p><b>Note: If excessive swinging does occur individuals must step away from the device</b>, and the winch operator must lower the sampling device into the water and wait for an appropriate moment to raise it.</p>
3	<p>Lower the device, controlling the descent and keep it at a speed that does not exceed <math>1 \text{ ms}^{-1}</math>.</p> <p>On descent, any sampling device will cause a bow wave which, if the sampler is lowered too quickly, will cause considerable disturbance to surface sediments.</p> <p><b>Note:</b> It is impossible to completely eliminate this pressure wave effect of the descending gear, although it can be greatly reduced by lowering as slowly as is practicable.</p>
4	<p>You must keep the warp as plumb as possible to ensure that the sampler is set down and lifted vertically.</p>

Step	Action
5	<p>Initial retrieval must not exceed <math>1 \text{ ms}^{-1}</math> on any occasion. Once free of the seabed, the winch-operator can increase the rate of retrieval, but this must not exceed <math>3 \text{ ms}^{-1}</math>.</p> <p>As hauling initiates the firing of some sampling devices, the speed of retrieval has a critical effect on the depth of sample. If you haul too quickly, the gear will be pulled free from the sediment before you obtain adequate sediment sample. This results in an unrepresentative sample, which you must reject.</p>

### Adjusting sample size

The weight of the sampler and the type of sediment encountered are important factors in determining the volume of sample obtained.

#### Action

Alter the weight of the sampler to achieve optimum bite into the sediment. Keep the volume of sample obtained as consistent as possible. You achieve this by altering the weight of the device with detachable lead weights.

### Acceptable sample size

Determine acceptable volume or depth of sample with reference to the Oslo and Paris Commission (OSPAR) recommendations ([Rumohr, 1999](#)). The recommendations give a minimum sample volume, below which a sample must be rejected. They are:

- grab samples less than  $5 \text{ dm}^3$  (at 7 cm depth) in muds;
- and less than  $2.5 \text{ dm}^3$  (at 5 cm depth) in hard packed sands;
- subtidal core samples must sample a minimum depth of 15 cm.

When gear is wedged open by stones or other detritus, material will be lost from the sampler during its ascent. On such occasions the sample must be rejected.

### Inspecting samples

Use the following procedure to inspect samples:

Step	Action
1	On retrieval, place the sampler securely on the stand with a suitable receiving container underneath.
2	<p>Make a visual inspection of the sample, for instance, through access doors on the top of the grab. Observe and measure the following:</p> <ul style="list-style-type: none"> <li>▪ the type of sediment;</li> <li>▪ colour;</li> <li>▪ smell;</li> <li>▪ depth of RPD layer (see <b>Note 1</b>);</li> <li>▪ texture and presence of surface features (accretions, algae, fauna);</li> <li>▪ depth of sample, taken with a ruler through the middle of the</li> </ul>

Step	Action
	<p>sampler, to the nearest cm (to calculate volume of material);</p> <ul style="list-style-type: none"> <li>photograph of sediment. Digital photographs are particularly useful as you can catalogue and store them electronically for future reference and used to verify sediment type (see <b>Note 2</b>). </li></ul> <p><b>Note 1:</b> RPD is the redox potential discontinuity layer, which is the part of the sediment where redox potential changes from positive to negative, that is, <math>E_h = 0</math>. This is often characterised by a change in sediment colour to black.</p> <p><b>Note 2:</b> It is advisable that the person responsible for photography is familiar with the camera to ensure that the shots of the sediment are in focus. Also observe the following:</p> <ul style="list-style-type: none"> <li>drain as much water as possible from the sampler to avoid light reflection from water films;</li> <li>on sunny days, ensure the sediment is shaded before taking the photograph;</li> <li>the photograph must capture the sides of the sampling device as well as the sediment (this provides further post-sampling information on the depth of the sample in the sampling device).</li> </ul>
3	<ul style="list-style-type: none"> <li>Record your observations and measurements (supporting parameters) on a field sheet (use the one in <a href="#">Appendix 3: Subtidal macrofaunal field record</a>).</li> </ul>

### Analysing samples

Analysis of benthic invertebrate samples invariably needs further supporting parameters such as Particle Size Analysis (PSA) and/or sediment chemistry. Confirm the requirement for PSA or sediment chemistry samples during the survey planning stage.

**Example:** CSEMP requires PSA and sediment chemistry; and PSA is a supporting parameter for WFD benthic invertebrate samples.

For advice on sediment sampling refer to [010\\_07 Sediment sampling in water for chemical and particle size analyses](#)

### Extracting samples

Use the following procedure when extracting samples from the sampling device:

Step	Action
1	Fully open the device so that the sample is released into the receiving container before onboard processing.
2	<p>To ensure complete transferral of the sample, you must wash the sampling device and run the washings into the receiving container. Do this carefully. You must reject the sample if:</p> <ul style="list-style-type: none"> <li>you wash material adhered to the outside frame of the sampler;</li> <li>you lose any sample over the side of the receiving container.</li> </ul>
3	You must wash the sampler thoroughly between sites to avoid cross contamination of samples.

**Labelling samples**

Add a suitable waterproof label to each sample with the following details on:

- survey,
- site,
- replicate code,
- and date.

This label must remain permanently with the sample as a unique identifier that can be used to track the sample for subsequent audit purposes. Write in pencil on waterproof-paper labels or use labels made of Dymotape.

---

**Decanting samples**

The sample and water from the washing of the sample device will cause the receiving container to be heavy. Use the following procedure to decant the receiving container:

Step	Action
1	Decant water out of the receiving container by tipping it and draining the water through a sieve of 0.5 mm or less, before lifting the receiving container between two people for further processing.
2	Any material retained on the sieve must be returned to the sample.

---

**Additional samples**

Further samples collected as replicates must be representative of the site and as identical as possible. If a different sediment type is hit, then retake this sample with the aim of being consistent in sediment type for all replicates.

---

**Important safety information for subtidal benthic sampling****Safety preparation**

Before undertaking work on any Environment Agency vessel all workers must:

- refer to [694\\_06 Safety measures while visiting coastal survey vessels](#);
  - refer to the boatwork instructions listed in [related documents](#);
  - be aware of vessel safety procedures and equipment.
- 

**Personal Protective Equipment (PPE)**

Observe the following safety information for PPE:

- you must wear a hard hat, steel toe-cap footwear and protective gloves when working with sampling gear;
  - when working on the deck of survey vessels, you must wear either:
    - a lifejacket with a D-ring;
    - OR, a harness with a D-ring worn beneath a non D-ringed lifejacket;
  - The D-ring allows attachment of a safety line. Safety lines must be worn in line with the instruction on safety lines in [694\\_06 Safety measures while visiting coastal survey vessels](#).
-

## Sampling device

Observe the following safety information when operating the sampling device:

- benthic grabbing must not take place in sea conditions that would warrant the need to attach a safety line. The winch and tilting A-frame ensure that you can deploy and recover the grab without the need to lean out over the back deck;
  - cease grabbing in conditions above Beaufort scale 3, unless the sea state is sheltered. Always seek advice from the vessel master, who has the final decision on all activities taking place;
  - be aware of fixed protruding structures on the deck, ensure you stow all equipment on deck securely and out of the path of workers on deck;
  - while the winch is in operation, all workers on the afterdeck are responsible for being aware of where moving machinery is, including the gantry, cables and drums. Workers must stay clear of these moving parts when in use;
  - do not obstruct the line of sight of the winch-operator when the sampler is being deployed and retrieved;
  - never place hands and fingers inside any mechanisms. Workers must guide gear with the flat of their hands placed on the outside of the device;
  - likewise, when setting sampling devices into firing position, or emptying the sample from the device, keep your hands and fingers clear of grab jaws;
  - two operators must set and empty the sampling device together in a co-ordinated manner;
  - only fit and able-bodied individuals must handle sampling gear, lift or move samples. All workers must be suitably trained in lifting techniques through manual handling training.
- 

## Handling samples

Observe the following safety information when handling samples:

- in order to minimise the weight of samples, use a minimum amount of water to wash the sample from the grab into the receiving container. Tip out excess water in the receiving container (through a sieve of mesh size 0.5 mm or less) before lifting the receiving container (between two people) up into the hopper;
  - arrange the grabbing equipment to ensure that you minimise the distance to carry the receiving container to the hopper and ensure that the route is clear of obstruction;
  - do not break up firm sediments by hand as there may be a danger of unseen sharp material in the sample;
  - always use a sieve stand, to avoid having to hold the sieve.
-

## Intertidal Sampling

---

### Contents

This chapter includes the following topics:

Topic	See page
<a href="#">Sampling considerations (intertidal)</a>	<a href="#">12</a>
<a href="#">Intertidal sampling devices</a>	<a href="#">13</a>
<a href="#">Intertidal sample collection competency</a>	<a href="#">13</a>
<a href="#">Intertidal sample collection</a>	<a href="#">14</a>
<a href="#">Important safety information for intertidal sampling</a>	<a href="#">16</a>

---

## Sampling considerations (intertidal)

---

### Sampling methods

In some circumstances you can obtain quantitative intertidal benthic samples from a boat at high tide using a benthic grab. However, if this is not possible you can collect them by using cores, for example, and accessing the sites by RIB (Rigid-hulled Inflatable Boat) or Hovercraft, or on foot at low tide.

**Important!** Intertidal soft sediments are hazardous environments. You must adhere to the operational instruction [13\\_07 Intertidal soft sediment work](#) and the [193\\_06 GRA Intertidal soft sediment work](#) when working in intertidal areas.

---

### Device types

Samples are taken using cores or box cores. The large box core can produce a considerable amount of material for processing. However, small diameter cores produce less material but necessitate the collection of more replicates.

---

### Sample depth

We use a minimum standard core depth of 15 cm.

The depth to which you obtain samples is an important factor, whatever type of core you employ. Samples taken to a depth of 15 cm will sample the majority of fauna.

[Barnett \(1984\)](#) noted that taking samples any deeper than 15 cm contributed little to the fauna compared with the time taken to sort the extra material, and [Smith \(1982\)](#), found that almost 100% of intertidal fauna in the Humber was present in the surface 10 cm of sediment. However, it may be necessary to sample to 40 cm in some sediments to obtain all deep dwelling fauna ([Wolff, 1987](#)).

Determine the correct sampling depth for any intertidal work in a pilot study, or by referring to the literature and/or previous work in the area to be investigated.

---

### Choosing a sampling device

The chosen sampling device must be able to sample efficiently in different sediments. Furthermore, you must consider whether the surface area sampled and the number of replicates taken adequately addresses the objectives of the survey.

Historically, we (and our predecessors) have predominantly used small hand corers (0.01 m<sup>2</sup>), employing large box cores (0.1 m<sup>2</sup>) on some occasions, particularly on more sandy sediments ([see NRA, 1993](#)).

## Intertidal sampling devices

[Appendix 1: Sampling devices](#) describes the following sampling devices:

- hand core (0.01 m<sup>2</sup>);
- intertidal box core (0.1 m<sup>2</sup>).

## Intertidal sample collection competency

You must have the required competency to carry out intertidal sample collection, or be under the supervision of a competent person. See Appendix 6 for a checklist to audit competency and quality of sample collection. Gain competency through the following process:

Stage	Description
1	View the Marine ecology sampling CD and complete the on-line assessment.
2	Read and understand: <ul style="list-style-type: none"> <li>▪ <a href="#">193_06 GRA: Intertidal soft sediment work</a></li> <li>▪ <a href="#">13_07 Intertidal soft sediment work</a>;</li> <li>▪ this instruction on marine benthic invertebrate sampling.</li> </ul>
3	Attend the water safety course.
4	Complete the e-learning tide-tables course.
5	Participate in intertidal soft sediment sampling work with a competent person at least <b>four</b> times.
6	You achieve competency when your team leader acknowledges you have developed sufficient skill. Your team leader must keep a record of competency. You must keep a copy as part of your training record.

## Intertidal sample collection

---

### Preparation

Consider an intertidal soft sediment environment a hostile one. There are specific measures to take and behaviours that you must follow to ensure that you manage the risks inherent in this type of work. For this reason you must refer to [193\\_06 GRA Intertidal soft sediment work](#) and the instruction [13\\_07 Intertidal soft sediment work](#), before planning any intertidal work.

In addition make a judgement of the necessity to go into the intertidal soft sediment environment.

---

### Site information report

Compile a site information report, which includes a site risk assessment. This must contain the following details:

- access and egress points to the site;
- any safety considerations;
- details of the survey, such as:
  - grid references;
  - latitude/longitude (with the datum clearly indicated);
  - landmarks (including site markers such as stakes and paint);
  - photographs.

These details will enable workers to relocate the site on subsequent sampling occasions. Review the site information report on each visit and update where necessary.

---

### Sampling

The type and number of cores required are dependent on the objectives of the survey, habitat and sediment type, and must be determined before commencing fieldwork. However, for temporal trends, collect a minimum of five cores. Use the following procedure when collecting samples:

Step	Action
1	<p>Take samples at a consistent tidal height (<math>\pm 0.2</math> m).</p> <p>Take each sample from an undisturbed area.</p> <p>Determine different shore heights at known states of the tide by referring to tide timetables.</p> <p>Visit these sites down the shore on a retreating tide. Cease sampling on or before low water. During survey planning, factor enough time into the plan to ensure a safe exit from the site. Keep in mind the distance to cover and the samples and equipment to transport.</p>
2	<p>There are two standard sizes for intertidal cores, a hand core (<math>0.01 \text{ m}^2</math>) and a box core (<math>0.1 \text{ m}^2</math>).</p> <p>Make sure the depth of the extracted sample is at least 15 cm to ensure the sample is representative of the macro-invertebrate community.</p>
3	<p>For the smaller core, the tube is extracted with the sample contained inside. The sample is then emptied into the sample container, taking care not to leave any residue inside the tube. For</p>

Step	Action
	the larger core, the sample has to be dug out of the core and placed into the sample container.
4	Transfer samples to clean water-tight containers such as plastic buckets or polythene bags (such as rubble sacks).
5	<p>Label containers with:</p> <ul style="list-style-type: none"> <li>▪ survey;</li> <li>▪ site;</li> <li>▪ replicate code;</li> <li>▪ date.</li> </ul> <p>Add a suitable waterproof label also containing this information to the sample. This label remains permanently with the sample as a unique identifier that we can use to track the sample for subsequent audit purposes.</p>

### Inspecting samples

Use the following procedure to inspect samples:

Step	Action
1	Make a visual inspection of the sample.
2	<p>Observe and measure the following:</p> <ul style="list-style-type: none"> <li>▪ the type of sediment;</li> <li>▪ colour;</li> <li>▪ smell;</li> <li>▪ depth of RPD layer (see <b>Note 1</b>);</li> <li>▪ texture and presence of surface features (accretions, algae, fauna);</li> <li>▪ depth of sample, taken with a ruler, to the nearest cm (to calculate volume of material);</li> <li>▪ photograph of sediment. Digital photographs are particularly useful as you can catalogue and store them electronically for future reference and to verify sediment type (see <b>Note 2</b>).</li> </ul> <p><b>Note 1:</b> RPD is the Redox Potential Discontinuity layer, which is the part of the sediment where redox potential changes from positive to negative, that is, <math>E_h = 0</math>. This is often characterised by a change in sediment colour to black.</p> <p><b>Note 2:</b> It is advisable that the person responsible for photography is familiar with the camera to ensure that the shots of the sediment are in focus. Also observe the following:</p> <ul style="list-style-type: none"> <li>▪ drain as much water as possible from the sampler to avoid light reflection from water films;</li> <li>▪ on sunny days, ensure the sediment is shaded before taking the photograph;</li> <li>▪ the photograph must capture the sides of the sampling device as well as the sediment (this provides further post-sampling</li> </ul>

Step	Action
	<p>information on the depth of the sample in the sampling device).</p> <ul style="list-style-type: none"> <li>For small core samples it may be more appropriate to photograph the sample once it has been placed in the sample pot/bag.</li> </ul>
3	Record these observations and measurements (supporting parameters) on a field sheet (use the one in <a href="#">Appendix 4: Intertidal macrofaunal field record</a> ).

### Analysing samples

Analysis of benthic invertebrate samples invariably needs further supporting parameters such as PSA and/or sediment chemistry. Confirm the requirement for PSA or sediment chemistry samples during the survey planning stage.

**Example:** CSEMP requires PSA and sediment chemistry; and PSA is a supporting parameter for WFD benthic invertebrate samples.

For advice on sediment sampling refer to - [010\\_07 Sediment sampling in water for chemical and particle size analyses](#)

## Important safety information for intertidal sampling

### Safety documents

Read section 3.4 of the operational instruction [13\\_07 Intertidal soft sediment work](#).

### Personal Protective Equipment (PPE)

Observe the following safety information for PPE:

- ensure the footwear you wear is close-fitting. Wear wellingtons or a dry/wet suit boot. If using corers, wear wellingtons with steel toe caps;
- wear waterproofs and layered clothing or a dry suit depending on the conditions or season. Dry suits are an option but their use will depend on the weather and distance to walk as they can lead to overheating. Any dry suit needs to be a good fit particularly around the foot to avoid excessive suction;
- Note:** Mud must not go past mid-calf level. Retreat to a safer area if this occurs.
- the use of sledges frees up the hands and is an improved manual handling technique for transporting samples compared to carrying buckets or a large number of heavy bags. It also reduces the exertion, as well as loss of balance and sinking caused by an individual carrying heavy items directly. Additionally, it provides a large surface area to lean on if needed to help work feet free of mud.

### Risk assessment

You must carry out a site risk assessment in the planning stages of the survey. Assess whether to carry out the survey on foot or by boat (such as RIB or hovercraft).

Carry out a dynamic risk assessment at all stages.

## Personnel

Observe the following safety information for personnel:

- intertidal soft sediments are a **hostile** and **remote** environment, a minimum of two people are required. All samplers must follow the Lone Worker procedure when working on them;
  - a **reliable** method of communication must be to hand to comply with Lone Worker procedure and to call emergency services if necessary (see the instruction [13.07 Intertidal soft sediment work](#) for more detail);
  - samplers must be physically fit, free of conditions causing shortness of breath and without limb, back or joint injuries;
  - a minimum of two samplers must be present. Both must be competent in intertidal soft sediment sampling if the site is new. When in-field training is required for competency, there must be a ratio of one competent sampler to one inexperienced sampler and the competent sampler must know the site well.
- 

## Environment conditions

Observe the following safety information regarding environmental conditions:

- plan surveys to take place during daylight hours;
  - carry out sampling with an ebbing tide, ending on or before low water;
  - your plan must include enough time to ensure a safe exit from the soft sediment area, taking into account the distance to return to hard ground and the need to transport samples and equipment;
  - weather can deteriorate even if you have a good forecast. Fog can be very local and can suddenly obscure your exit route. The loss of visibility and muffling of sound can cause disorientation. If this happens, use your footprints to retrace your steps immediately and return to hard ground.
-

## Sample processing

### Contents

This chapter contains the following topics:

Topic	See page
<a href="#">Sample processing</a>	<a href="#">18</a>
<a href="#">Sieving</a>	<a href="#">20</a>
<a href="#">Fixing</a>	<a href="#">21</a>
<a href="#">Important safety information for using formaldehyde</a>	<a href="#">22</a>

## Sample processing

### Processing

Once a benthic macro-invertebrate sample has been collected it must be reduced to a more manageable volume. To achieve this, the sample is sieved to reduce the amount of sediment.

The material retained is potted, chemically fixed and forwarded for laboratory analysis to identify the fauna present.

An overall view of this processing of samples is as follows:

Stage	Description
1	Remove sediment by washing the sample through a sieve. The mesh size of the sieve is critical in determining what fauna are extracted from the sample. See <a href="#">Mesh size</a> for information on this.
2	Hoppers are used to aid the sieving process. The hoppers allow the sample to be agitated with excess water, suspending the sediment and fauna into the water; the water is then released at intervals onto the sieve in a controlled manner.  We commonly use two hoppers, the Muse hopper (also known as the tilting hopper) and the gated hopper.  See <a href="#">Appendix 2: Hopper devices</a> for a description of each. The section <a href="#">Autosiever</a> describes an alternative to the hopper.
3	Assess the manual handling steps to transfer the receiving container holding the sample up into these hoppers and take measures to reduce or eliminate the need to lift the sample. At minimum, drain away the excess water in the receiving container by tipping it and passing the water through a sieve (0.5 mm or less), so that no sample material is lost.
4	Once the excess water has been decanted off, lift the container between two people to the hopper available. <b>You must return any sample retained on the sieve to the bulk sample.</b>
5	Follow sieving by chemical fixation of the sieved samples as soon as possible (must be within 24 hours of collection) in order to maintain the quality of the sample. <ul style="list-style-type: none"> <li>Best practice is to return to the laboratory to carry out the addition of fixative using a fume cupboard (follow <a href="#">Ecology</a></li> </ul>

Stage	Description
	<p data-bbox="587 203 815 237"><a href="#">laboratory safety</a>)</p> <p data-bbox="539 253 1414 387">However, in circumstances where it is not practical to reach a laboratory with a fume cupboard, sieving and fixing of samples can occur on board a coastal survey vessel (CSV) (see <a href="#">Fixing</a> for information on fixing samples).</p> <p data-bbox="539 405 1422 465">Fixing of samples in any other circumstance is subject to a full local risk assessment.</p>

**Mesh size**

As a general rule use a mesh size of 0.5 mm in transitional waters and 1 mm in coastal waters.

Consistent use of mesh sizes ensures that all resulting data can be used for more than one purpose and data is comparable across surveys. Always follow this mesh size protocol, unless there is a specific investigative or R&D reason for deviating to another mesh size.

**Autosiever**

An alternative to the hoppers is an autosiever. The autosiever is an enclosed device, which sprays water through the sieve from underneath, via a pumped supply. This breaks up the sediment while at the same time keeping the invertebrates off of the sieve mesh, avoiding impingement of invertebrates on the mesh.

## Sieving

### Do's and don'ts

Observe the following do's and don'ts when sieving:

- only carry out sieving with sieves that conform to the British Standard BS 410. Replace sieves at the first signs of damage to the mesh;
- do **not** wash samples with a direct jet of water against the sample on the mesh as this can damage fragile invertebrate fauna;
- when using the gated hopper, the gate can be closed and the hopper filled with water to allow 'puddling' of the sieve in the water. This breaks up the sediment whilst keeping the fauna suspended, avoiding impingement on the sieve mesh;
- do **not** break up firm sediments by hand due to the danger of unseen sharp material in the sample;
- avoid long sieving times as invertebrates may actively pass through the sieve ([ISO, 2001](#));
- do **not** routinely use scoops and spoons to transfer material from the sieve into a sample container, except where large bulky sandy/gravel samples are collected. In these cases, you must transfer samples carefully to avoid scraping the sample on the mesh. You can then transfer the residual, fine material by back-washing;
- throughout the sieving process take care to avoid sample loss during sieving. Using a double sieve can facilitate this; that is, processing the sample in a sieve sitting inside a larger diameter sieve of the same mesh size (or less), to catch any material inadvertently lost from the sample. You must reject a sample if material is lost.

### Sieving procedure

Use the following procedure when sieving:

Step	Action
1	Break down the samples in the receiving container using only gentle water pressure. Use the tilting hopper to move the accumulated water back and forth, to agitate the sediment, then tip the sediment in suspension down the chute, and onto the sieve.
2	During sieving, remove large animals, stones and large shells to minimise any grinding effects on the fauna and sieve. Place large specimens, stones, shells in a separate sample container to the remainder of the sample, and label it appropriately, in order that the full sample is analysed at the laboratory. However, you can discard stones or empty shells devoid of epifauna, so long as there is no reason to keep them for the purpose of the survey.
3	The sieved sample (on the sieve) may need to be photographed (for instance, WFD sampling requests this record to be made, check for this requirement during your survey planning stage).
4	Wash all material retained on the sieve into a labelled, water-tight container with a gentle stream of water. A sampling funnel can be used to aid this and use as little water as possible.

Step	Action
5	Check the sieve thoroughly for any fauna enmeshed on the sieve. Remove these carefully with forceps and place in the sample container.  <b>Note:</b> Containers must have airtight lids, wide mouths, be robust and not have more than a five-litre capacity.
6	If you transfer the sample with too much water it can reduce the fixing efficiency of the fixative solution, so decant this water off through a sieve.  Transfer any material caught on the sieve back to the sample using forceps or with a minimum of water using a wash bottle.
7	Wash all processing equipment thoroughly between sites, including scrubbing the sieves, to avoid cross-contamination.

## Fixing

### Definition

Fixation is the process of maintaining cells and tissue constituents in as close to a life-like state as possible. It arrests autolysis and bacterial decomposition and stabilises the cellular and tissue constituents so that they withstand the subsequent stages of processing. Chemicals capable of fixing cells and tissues are very hazardous. The fixative chemical we use for marine invertebrate samples is Formaldehyde aqueous solution.

### Formaldehyde

Formaldehyde is a gas that dissolves readily in water. It is a small molecule (formula: HCHO, of which the -CHO is the aldehyde group). Formaldehyde solution used, is an aqueous solution of formaldehyde and contains 37-40% of formaldehyde and 60-63% of water (by weight). Where the word formaldehyde is used in this instruction it refers to formaldehyde aqueous solution (that is, 37-40%, known as stock solution of formaldehyde); dilution of formaldehyde solutions are referred to specifically, such as, 4% formaldehyde ([Entec, 2005](#)).

### Monitoring exposure to formaldehyde

Monitoring of staff exposure to formaldehyde fumes must be undertaken and any exceedence of Operational Exposure Limits (OELs) acted upon. Workplace Exposure Limits (WELs) of 2 ppm both in the long term, 8-hour Time Weighted Average (TWA) and the short-term, 15 minutes Short Term Exposure Limit (STEL) must not be exceeded. Formaldemeters are the most widely used method for monitoring. For more details on monitoring see the instruction [52\\_05 Ecology laboratory safety](#).

### Fixing samples

Use the following procedure when fixing samples:

Step	Action
1	Fix marine invertebrate samples using 4-10% formaldehyde.  Make this solution by diluting 40% formaldehyde with seawater (1:9

Step	Action
	<p>dilution, for 4% formaldehyde).</p> <p><b>Note:</b> Generally 4% formaldehyde is sufficient, however, particularly organic muds require up to 10% formaldehyde to ensure that they are adequately fixed.</p> <p>Use the following ratios:</p> <ul style="list-style-type: none"> <li>▪ for muds: use a 3:1 ratio of formaldehyde (diluted) volume to sample volume;</li> <li>▪ for sandy samples: use a 2:1 ratio of formaldehyde (diluted) volume to sample volume;</li> </ul>
2	<p>It is imperative that you add a buffer to ensure a neutral pH. This will prevent dissolution or etching of shells or other calcareous structures (<a href="#">Hartley et al. 1987</a>).</p> <p>Achieve buffering by using disodium tetraborate (also known as Borax) in the ratio of <b>30g per litre of 37-40% formaldehyde for a strength of 4% formalin</b>, or by using calcium carbonate or marble chips.</p> <p><b>Note:</b> Borax causes lysis and bleaching over time, so samples must be analysed promptly (certainly within the year of collection). Calcium carbonate and marble chips provide only a minimum precaution to prevent the development of acidic conditions (<a href="#">Eleftheriou &amp; Holme, 1984</a>). You must adhere to <a href="#">COSHH</a> risk assessments.</p>
3	<p>Tip the sample to mix in the fixative (ensuring that the lid of the pot is fitted tightly) and allow a minimum of 12 hours for fixation (ISO, 2001)</p> <p>Carry out fixing of samples within 24 hours of collection.</p> <p><b>Note:</b> To ensure that fixation has completely occurred, particularly in very organic or gravel laden sediments, at least 72 hours is recommended.</p>

## Important safety information for using formaldehyde

### In the laboratory

Use a fume cupboard and follow the instruction [52\\_05 Ecology laboratory safety](#).

## Onboard the coastal survey vessel (CSV)

In the first instance, if it is feasible to do so, travel to a laboratory equipped with a fume cupboard to fix samples on the day of collection. If it is not feasible, the fixing can be done onboard the CSV:

Observe the following safety information when onboard a CSV:

- seek the master's permission ahead of time to bring formaldehyde on board and provide a COSHH assessment;
- the leader of the team bringing formaldehyde on board must identify themselves to the master and survey officer. The leader is responsible for the safe use of the chemical (and safe clear up of chemical if a spill occurs);
- only use or store formaldehyde (securely, within a secondary container) on the open deck (in an area designated by the master), it must never be brought into the cabins or hold;
- only competent persons are to use formaldehyde and only when wearing full PPE (chemical resistant gloves (EN374, Class III), eye protection (goggles/face mask – EN166) , full wet weather gear/footwear); . A recent audit of this activity has concluded there is a potential risk of exceeding WEL for formaldehyde and recommends the use of a respirator to the standard (EN140 mask with a combined organic vapour filter(s) EN141).
- a spill kit must be to hand;
- you must only carry out the dispensing of formaldehyde from a stable platform in calm conditions, non-essential individuals to the task must stay clear. Only use plastic containers;
- ensure the deck hose is on when fixing samples in case a spill occurs;
- label all sample containers with 37-40% formaldehyde solution as TOXIC and FLAMMABLE, those with 4-10% formaldehyde as HARMFUL.

## Spills

Observe the following safety information for spills and spillages:

- for spills in the laboratory see the instruction [52\\_05 Ecology laboratory safety](#);
- when on-board a CSV, a spill kit must always be to hand;
- you must alert all personnel immediately when a spill occurs. Wear full PPE (chemical resistant gloves (EN374, Class III), eye protection (goggles/face mask – EN166), full wet weather gear/footwear); wearing appropriate face mask for vapours (EN140 mask with a combined organic vapour filter(s) EN141). Dispose of waste as per the ecology laboratory operation instruction.
- Use the following procedure for dealing with spills.

Step	Action
1	Respond to a spill rapidly using either: <ul style="list-style-type: none"> <li>▪ large-scale dilution with available hoses to open water;</li> <li>▪ or, in contained areas such as marinas, by using Spill-X-FP. Spill-X-FP formaldehyde polymerizer is contained in the Formaldehyde and solvent spill treatment kit.</li> </ul>
2	When fully absorbed, sweep up the Spill-X-FP formaldehyde polymerizer. Seal in a plastic bag using the equipment provided in the spill kit.

Step	Action
3	Label the bag as hazardous, transport it to a laboratory following the measures laid out for transport of formaldehyde (see section on <a href="#">Transport</a> below). Arrange disposal, following the method set out in the instruction <a href="#">52_05 Ecology laboratory safety</a> .

### Transporting formaldehyde

Observe the following safety information when transporting formaldehyde:

- plan ahead to ensure that you transport only the minimum amount of stock solution;
- in case of leaks or spills you must wear the correct protective clothing (eye protection, gloves and footwear) when loading/unloading sealed fixed samples or dilute/undilute formaldehyde in their primary containers;
- you must follow the instructions in [368\\_07 SD10 Transport instruction for formaldehyde](#) when transporting formaldehyde.
- If a spill should occur, use the same procedure and equipment as detailed above under “Spills”.

### Transporting formaldehyde by courier

Observe the following safety information when transporting formaldehyde by courier:

- the courier company must be fully aware of what they are carrying;
- the courier company must be vetted to ensure the safety precautions on transporting formaldehyde are followed.

### Storage

Observe the following safety information for storing samples:

- storage of fixed samples must be within an approved ventilated store (see the instruction [52\\_05 Ecology laboratory safety](#));
- storage of stock formaldehyde is in the corrosive chemical cabinet, never store with strong oxidising agents, such as hydrochloric acid;
- it is best practice to analyse, quality assure and dispose of samples within the year of collection. Carry out an annual review to ensure samples are not stored long term or unnecessarily and remove unnecessary samples.

## Appendix 1: Sampling devices

### Contents

This chapter includes the following topics:

Topic	See page
<a href="#">Day Grab</a>	<a href="#">25</a>
<a href="#">Van Veen grab</a>	<a href="#">27</a>
<a href="#">Box corer</a>	<a href="#">28</a>
<a href="#">Hand core</a>	<a href="#">30</a>
<a href="#">Box core</a>	<a href="#">31</a>

### Day Grab

#### Description

The day grab shown in [Figure 1](#) is of a standard size (0.1 m<sup>2</sup>). It is a remote sampler primarily used to obtain quantitative macrofaunal samples from coastal and estuarine soft sediments. However, it is also used to obtain sediment samples for particle size analysis, metal, organics and carbon analysis. Due to its weight, you will need a boat equipped with a winch and gantry to deploy and retrieve the grab.

The grab consists of two hinged jaw buckets mounted within a supporting pyramid-shaped frame. This design makes the grab more robust and stable so that it is unlikely to upend during use, especially in poor weather conditions. The jaw buckets are fabricated from stainless steel, while the frame may also be constructed from stainless steel or galvanised mild steel. The shape of the jaw buckets is a quarter-cylinder, so that when they close they form a large semi-cylindrical bucket.

**Figure 1: Day grab**

See [Operating the day grab](#) below for an explanation of annotations.

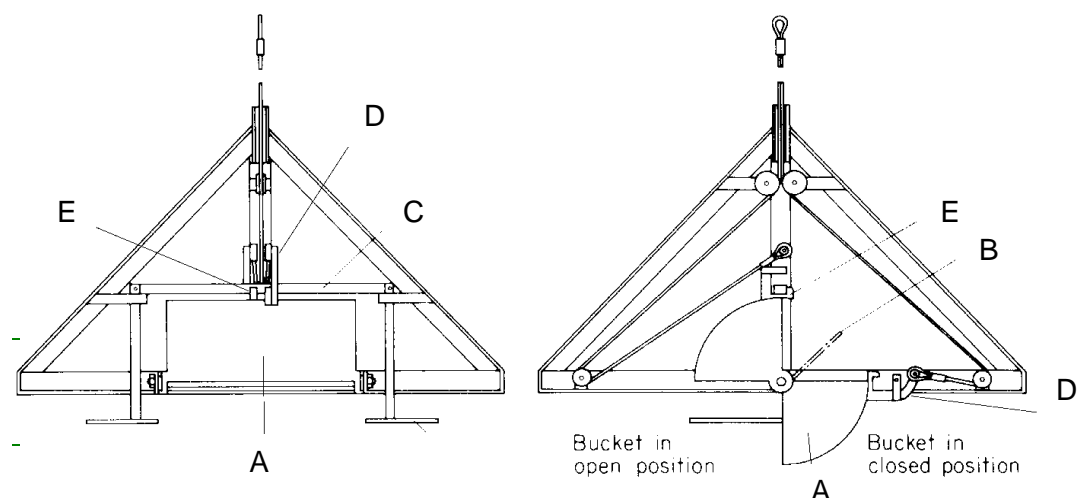

## Operating the day grab

A total of three workers must operate the grab; one controlling the winch (the winch operator is a qualified crew member), and two working at the grab. Where available, use a grab dampener to minimise swinging.

**Note:** When onboard the grab must always be positioned on its stand.

Use the following procedure and refer to the diagram in [Figure 1: Day grab](#).

Step	Action
1	<p>The grab must be cocked before you deploy it:</p> <ul style="list-style-type: none"> <li>▪ before cocking, fasten the lids (B) on the buckets shut</li> </ul> <p>Set the jaw buckets (A) in the open position (<a href="#">Figure 1</a>). To do this:</p> <ul style="list-style-type: none"> <li>▪ with a co-worker, stand either side of the sampler and cock the jaws together;</li> <li>▪ lift the transverse retaining beam (C) with one hand, while pushing the jaws open with the other hand, using the bars (D) attached to the buckets;</li> <li>▪ when the buckets are fully opened, drop the retaining beam into position so that it retains the catches (E) on the buckets and the grab remains cocked.</li> </ul>
2	Lift the grab above the level of the transom by the winch and then direct it outboard using the hydraulic gantry, while the two workers manually control any swinging.
3	<p>Once clear of the stern, commence lowering.</p> <p>As the grab settles on the sea bed the plates push the retaining bar up, releasing the jaws, which bite into the sediment. The warp is attached to arms on each jaw bucket, so that the closure of the jaws is completed by mechanical leverage against the grab when hauling commences.</p> <p><b>Note:</b> You can alter the weight of the grab by attaching lead weights to the frame to achieve efficient penetration on a variety of sediments.</p>
4	On retrieval, lift the grab above the level of the transom. Bring the grab inboard and lower onto the stand using two workers to guide it.
5	Securely position the grab on the stand and disengage the hydraulics for the winch.
6	<p>Open the lids and examine the sample.</p> <p>Take any sub-samples of surface sediments or undisturbed cores you require and make observations of the sediment/water interface.</p>
7	The two workers may drain off any surface water by levering the jaws open very slightly using the bars on the buckets. Alternatively, you can siphon the water off with a length of tubing to minimise the loss of flocculent surficial sediments.
8	After completing all inspection and sub-sampling, empty the grab by fully opening the buckets. Ensure that there is sufficient slack on the warp to allow full opening of the grab. If the sample does not readily come out, encourage it by vigorously banging the buckets against the retaining beam.

## Van Veen grab

---

### Description

The Van Veen grab (see [Figure 2: Van Veen grab](#)) is a remote sampler primarily used to obtain sediment samples from coastal and estuarine soft sediments, for both biological and physico-chemical studies.

The Van Veen grab is available in many sizes (0.1 m<sup>2</sup>, 0.05 m<sup>2</sup>, 0.025 m<sup>2</sup>). The 0.1 m<sup>2</sup> must be deployed from a CSV using the winch. The 0.05 m<sup>2</sup> may be deployed from CSVs and small boats equipped with a winch. The 0.025 m<sup>2</sup> Van Veen grab is a hand held grab, used for the collection of sediment samples and operated by ropes attached to each arm. When a winch is used, the manning levels are as for the day grab. The hand held grab can be operated by one person.

The grab consists of two hinged self supporting jaw buckets with long arms attached to each bucket through which the warp passes. The arms help to prevent the grab being jerked off the sea floor should the survey vessel roll as the grab is closing. The whole grab is fabricated from stainless steel. The shape of the jaw buckets is a quarter-circle, so that when they close they form a large bucket, which is semicircular in cross-section.

---

**Figure 2: Van Veen grab**

The following picture shows the Van Veen grab.

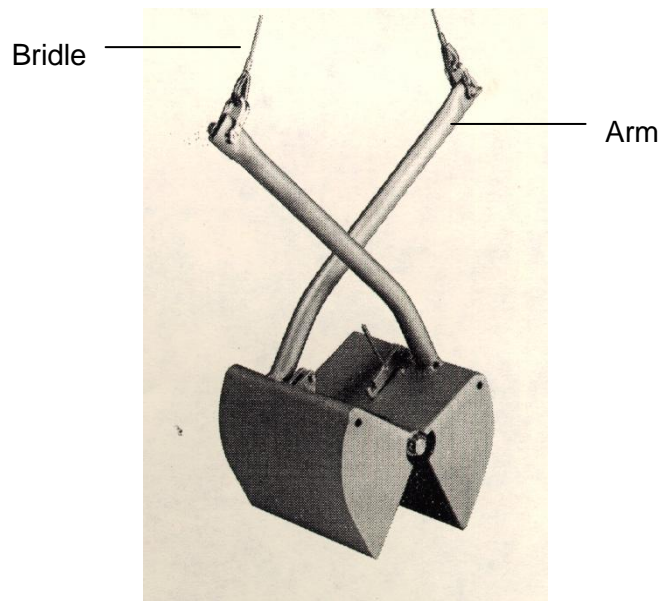

## Operating the Van Veen grab

Use the following procedure when operating the Van Veen grab:

Step	Action
1	<p>Before deploying the Van Veen grab:</p> <ul style="list-style-type: none"> <li>▪ fasten the lids on the buckets shut;</li> <li>▪ make sure the grab is cocked by: <ul style="list-style-type: none"> <li>▪ pushing the arms apart to open the jaws;</li> <li>▪ lifting the locking bar into place.</li> </ul> </li> </ul> <p><b>Note:</b> The bar will only be held in place automatically when the strain is taken up during lifting of the grab.</p>
2	<p>When deploying from a CSV, lift the grab above the level of the transom using the winch and then direct it outboard using the hydraulic gantry. Workers must control any swinging manually. Once clear of the stern, commence lowering.</p>
3	<p>While deploying the grab, minimise any drifting of the survey vessel as the grab is easily toppled when on the sea floor.</p>
4	<p>During retrieval, lift the grab above the level of the transom, and bring inboard, guiding manually, and lower onto the deck or into a receiving container.</p>
5	<p>Once the grab is on deck, open the lids, examine the sample and collect the sub-samples.</p>
6	<p>After you complete your inspection and sub-sampling, empty the grab by fully opening the buckets.</p>

## Box corer

### Description

The box corer (see [Figure 3: Box corer](#)) is a remote sampler we employ to collect sediment samples from marine and estuarine soft bottoms. We use the samples primarily for biological studies, although we may also use cores for physicochemical samples and measurements.

### Structure

The corer consists of a removable coring tube and a hinged spade that you pull down to close the end of the core. The coring tube is mounted under a sliding piston assembly that pivots within a supporting steel frame. This design allows the corer to penetrate consistently, even on rough substrates, and makes it more stable so that it is unlikely to upend during use.

The tube is square, with a cross sectional area of 0.025 m<sup>2</sup>, and is made of stainless steel. However, there are corers with round structures, such as the 'HAPS' design.

The frame may be made of stainless or galvanised steel. You can alter the weight of the coring assembly by attaching lead weights to the frame to achieve efficient penetration in a variety of sediments.

### Description of coring process

The corer is deployed in the cocked position, which is maintained by the release hook on the apex of the corer. The hook releases when the corer settles on the seafloor and the weight transfers from warp to frame. The weight of the coring assembly then pushes the core tube into the sediment.

Rubber flaps allow water to escape from the core as it is pushed into the sediment. The warp is attached to the spade arm, so that as hauling commences the spade is pulled through the sediment until it closes the end of the tube. Lifting the corer off the seabed transfers the weight of the coring assembly to the rubber covered spade, thus effectively retaining the sample.

On retrieval the core tube is removed, which allows access to the sample. This enables sub-samples to be taken of surface sediment and for any direct observations to be made.

### Figure 3: Box corer

The following picture shows the box corer.

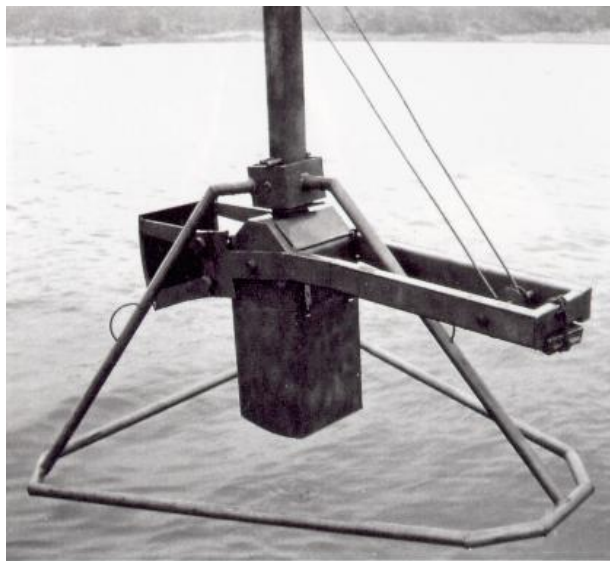

### Operating the box corer

Use the following procedure below when operating the box corer. Observe the following important points:

- due to its weight, you will need a boat equipped with a winch and gantry to deploy and retrieve the corer;
- a total of three workers must operate the corer; one controlling the winch, and two handling the corer;
- before use you must ensure that the corer is serviceable, with special reference made to the spade actuating wire, which must be replaced at least every two years;
- between sites, or while transporting, you must leave the corer uncocked;
- you must only attach the core tube and spade when the corer is uncocked and the piston is secured with the retaining pin.

Step	Action
1	When deploying from a CSV, lift the box corer above the level of the transom using the winch and then direct it outboard using the hydraulic gantry. Workers must control any swinging manually. Once clear of the stern, commence lowering.

Step	Action
2	Once settled on the seafloor, allow sufficient time for the corer to penetrate into the sediment before you commence retrieval.
3	On retrieval, lift the corer above the level of the transom, bring it inboard and lower it onto the deck.
4	Before removing the sample you must wash the corer thoroughly to remove any sediment adhering to the outside of the spade and the core tube inner.
5	Once the corer is on the deck open the drainage window to allow surface water to escape.
6	Remove the securing pins. This releases the core tube. Loosen the hinged bolts to release the spade. Remove the core tube and spade together, with the spade preventing the sample from being lost.  <b>Note:</b> Once the retaining and safety pins have been removed, hands and fingers must not be placed within the frame, or between the cutting arm and main body of the corer, and workers must not interfere with the warp. You must guide the sampler by the frame only.
7	Raise the piston of the corer and secure using the retaining pin.
8	Move the core tube carefully from the spade onto an extruder of the same surface area as the core.  Remove the core by pushing the tube down over the extruder and cut the core at the required sample depth.

## Hand core

### Description

The hand core is a simple hand held device we use for sampling intertidal soft sediments primarily for macrofaunal studies. The corer is made up of a length of 11.3 cm internal-diameter, stainless steel tubing. There are two handles at top of the core, and a marker on its external surface 15 cm from its cutting edge. You can also use a plunger of the same dimensions as the internal diameter of the corer, or a rubber bung of the right size to fit one end of the tube.

### Operating the hand core

Use the following procedure below when operating the hand core. Observe the following important points:

- you must refer to the instruction, [13\\_07 Intertidal soft sediment work](#); and [193\\_06 GRA Intertidal soft sediment work](#);
- you must only undertake sampling in intertidal environments if you are suitably fit and able-bodied;
- you must be suitably trained in lifting techniques.

Step	Action
1	Holding the core by its handles, place it vertically on the sediment surface and push the core straight down until it is buried up to the 15 cm mark.
2	To remove the core, rotate and rock it to overcome the cohesive nature of the surrounding sediment, then pull it out. <b>Notes on extraction:</b> <ul style="list-style-type: none"> <li>▪ in particularly cohesive sediment it may be necessary to free the corer at its base by hand or using a spade;</li> <li>▪ remove the core swiftly after being inserted so that deeper burrowing animals do not escape;</li> <li>▪ where sediments are particularly soft, insert the bung into the top of the core so that the sample is retained by suction as the sampler is pulled from the sediment.</li> </ul>
3	Remove samples from the corer by using the plunger on the underside to push the sample out of the top of the corer. <b>Note:</b> Extremely soft cores will fall out as soon as the bung is released.

## Box core

---

### Description

The box core is a simple hand held device used for sampling intertidal sediments.

---

### Procedure

Push the box core into an undisturbed area of sediment and dig the sediment within out to a depth of 15 cm using a scoop or small spade.

---

## Appendix 2: Hopper devices

### Contents

This chapter includes the following topics:

Topic	See page
<a href="#">Muse hopper (tilting hopper)</a>	<a href="#">32</a>
<a href="#">Gated hopper</a>	<a href="#">33</a>

### Muse hopper (tilting hopper)

#### Description

The Muse hopper ([Figure 4: Muse hopper](#)) facilitates the processing of large sediment samples from marine and estuarine soft bottoms. The device enables the gentle breaking down of samples before transferring them to a sieve as a sediment/water suspension, while eliminating much of the physical effort involved in other processing techniques.

The hopper has a tilting cradle that holds the sample container. A ratchet maintains the cradle at an angle while you wash the sample, with material directed to a sieve by a chute positioned below the cradle. You can alter the angle at which the cradle is held so that as the sample reduces the angle of tilt can be adjusted to allow complete transferral of material to the sieve.

#### Figure 4: Muse hopper

In the picture of the tilting hopper (A), the ratchet allows the tipping back and forth of the receiving container, followed by tilting sediment/water suspension down the chute to the sieve in picture (B).

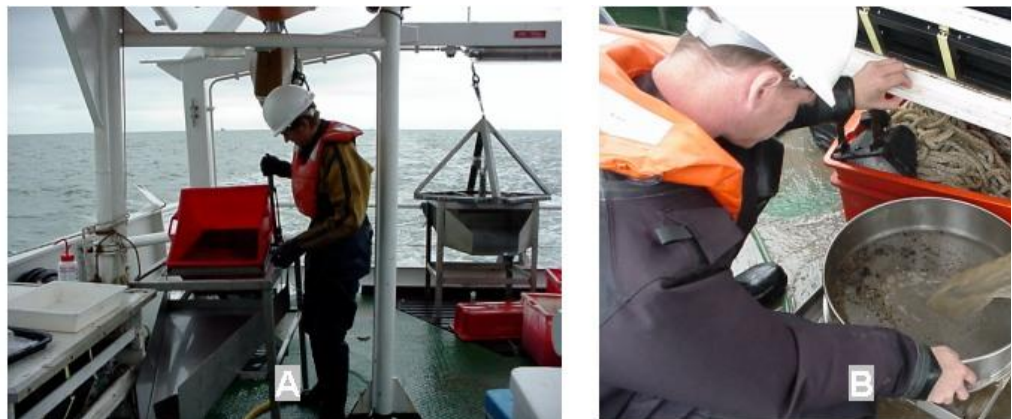

### Using the Muse hopper

Observe the following important notes when using the Muse hopper:

- when a sample is positioned in the cradle a large diameter sieve must be positioned at the mouth of the chute at all times;
  - when transferring samples into the cradle ensure that no material is lost. If loss occurs you must reject the sample;
  - break down samples as gently as possible using gentle water pressure and gradually run them into the sieve, altering the angle of the cradle to regulate the rate of dispersal;
  - wash the tilting hopper thoroughly between samples to avoid cross-contamination.
- 

## Gated hopper

---

### Description

The gated hopper is a hopper with a chute that can be closed off by a gate ([Figure 5: Gated hopper](#)). Sediment is gently broken down and gradually run into a sieve, using the gate on the hopper to regulate the rate of dispersal. For further washing, the hopper can be part filled with water and the sample 'puddled' gently in the sieve. A second sieve of the same mesh size is positioned to collect any material accidentally washed out of the sample.

---

### Figure 5: Gated hopper

This figure shows a hopper with a gate to control the flow of sediment suspension in water to the sieve.



### Using the gated hopper

Observe the following important notes when using the Muse hopper:

- position a sieve of appropriate size at the mouth of the chute at all times. Do not rely upon the gates of the hopper to completely seal the sample in the hopper;
  - in order to aid the breakup of sample, 'puddle' a sieve containing sample in a hopper that has had water added to it;
  - take care when opening the gate to control the flow of water into the sieve so that there is no loss of sample;
  - wash the hopper thoroughly to ensure no sample is missed and to avoid cross-contamination with further samples.
-



**General comments**

**Example:** Site observations, presence of slicks, number and size of sample pots)

**Key to sediment types and textures****Types**

Mud (M)

Sandy mud (SM)

Muddy sand (MS)

Sand (S)

Gravelly sand (GS)

Sandy gravel (SG)

Gravel (G)

**Textures**

Fluid (I)

Soft (s)

Firm (f)

**Example:** Soft Muddy Sand = SMS

**Observations**

Include the following in your observations:

- colour;
- smell;
- stability (stable-mobile);
- sorting (well-poor);
- surface relief (even-uneven);
- depth of RPD layer;
- accretions (such as coal, illmenite);
- surface flora/fauna;
- presence of burrows, casts and tubes.

## Appendix 4: Intertidal macrofaunal field record

---

**Note** Complete in black? ink. Initial and date any corrections.

---

Survey	
Site	
Position fix/NGR	
Shore height:	

Date	
Time	
Sampling device	
Sampler name	

### 'Core' method

Sampling Device (such as 0.01 m<sup>2</sup> corer): \_\_\_\_\_

Sample no.	Container code	<a href="#">Sediment type/ observations</a>	Sieving observations	Sieved by

**Sub-samples:**      Metals                      PSA                      Organic carbon  
                                  Organic chemicals      Coal                      Bacteriological

Sheet continues on next page.

**Supplementary Samples**Sampling device (such as 0.25 m<sup>2</sup> box corer/0.01 m<sup>2</sup> corer): \_\_\_\_\_

Sample no.	Container code	<a href="#">Sediment type/ observations</a>	Sieving observations	Sieved by

**Key to sediment types and textures****Types**

Mud (M)

Sandy mud (SM)

Muddy sand (MS)

Sand (S)

Gravelly sand (GS)

Sandy gravel (SG)

Gravel (G)

**Textures**

Fluid (l)

Soft (s)

Firm (f)

**Example:** Soft Muddy Sand = SMS**Observations**

Include the following in your observations:

- colour;
- smell;
- stability (stable-mobile);
- sorting (well-poor);
- surface relief (even-uneven);
- depth of RPD layer;
- accretions (such as coal, illmenite);
- surface flora/fauna;
- presence of burrows, casts and tubes.

## Appendix 5: Macrobenthic invertebrate sampling CSV: Competency Audit

### Note

This checklist is to ensure that all our staff carrying out marine benthic invertebrate sampling adheres to Environment Agency procedures for health and safety and to maintain data quality.

Marine sample collection must be carried out by a competent person, or under the supervision of a competent person. Your team leader must keep a record of competency. You must keep a copy as part of your training record.

Name:	Survey:
Role: Technical lead / Trainee	Date:
Auditor:	Job description:

<b>Pre-work:</b>	
Viewed and completed assessment on Marine Ecology Sampling CD	Yes/No
Read and fully understood the following GRA's? <ul style="list-style-type: none"> <li>• Working in or near water</li> <li>• Boatwork</li> <li>• Grabbing, coring and trawling from Environment Agency vessels</li> </ul>	Yes/No Yes/No Yes/No
Read and fully understood the following work instructions and Guidance? <ul style="list-style-type: none"> <li>• Lifejacket and buoyancy aid including servicing bulletins</li> <li>• Marine benthic invertebrate sampling and processing</li> </ul>	Yes/No Yes/No
Visitors to coastal survey vessels	Yes/No
Completed the following H & S training? <ul style="list-style-type: none"> <li>• Manual Handling</li> <li>• Water Safety or Sea survival</li> </ul>	Yes/No Yes/No
Previously carried out sample collection under supervision (note how many)?	Yes/No
Clear regarding the aims and requirements of the survey?	Yes/No
<b>Arrival at vessel:</b>	
Staff has fully compliant PPE	Yes/No
Staff has notified Master of any chemicals to be bought onboard (COSHH assessment provided ahead of time) and arranged for secure storage with the master	Yes/No
Understand procedures if a chemical spill occurs (Include use of spill kit)	Yes/No
Staff have received vessel safety briefing on board	Yes/No
Staff have received activity briefing	Yes/No
Staff have clearly communicated aims of survey, specific requirements, any change of plans to Master and SO	Yes/No
<b>Sample Collection:</b>	
Do you understand the responsibilities of each staff member? (Who is recording position/depth/salinity/sample no. and so on)	Yes/No
When using the sampling equipment, have the guidelines set out in the benthic sample collection guidance been adhered to?	Yes/No
Sample integrity maintained (discarded where inappropriate)?	Yes/No
Supporting parameters recorded? (Sediment type, anoxic layer, sample vol, digital image, surface features)	Yes/No
Consistent labelling of samples (sites, samples, logs and digital images)	Yes/No
Correct manual handling technique employed (for example remove excess water prior to lifting)	Yes/No

<b>Sample Processing:</b>	
Was sieve processing procedure followed? (Correct manual handling, gentle flow of water, back washing technique, picking of sieve with tweezers)	Yes/No
Sieve cleaned to prevent cross contamination?	Yes/No
<b>Sample Preservation:</b>	
Staff trained in the use of formaldehyde (understanding of formaldehyde H & S, strength of preservative to be used, buffered, volume required)?	Yes/No
Was the correct protective equipment worn whilst the preservative was being used?	Yes/No
Sample pot clearly labelled with correct information?	Yes/No
Provision for the safe transport of samples in place (for example trailer, separate cab, correct labelling)	Yes/No
Notes:	
Signature:	
Date:	

## Appendix 6: Macrobenthic invertebrate sampling on foot: Competency Audit

### Note

This checklist is to ensure that all our staff carrying out marine benthic invertebrate sampling adheres to Environment Agency procedures for health and safety and to maintain data quality.

Marine sample collection must be carried out by a competent person, or under the supervision of a competent person. Your team leader must keep a record of competency. You must keep a copy as part of your training record.

Name:	Survey:
Role: Technical lead / Trainee	Date:
Auditor:	Job Description:

<b>Pre-work:</b>	
Viewed and completed assessment on Marine Ecology Sampling CD	Yes/No
Read and fully understood the following GRA's? <ul style="list-style-type: none"> <li>• Working in or near water</li> <li>• Intertidal soft sediment work</li> </ul>	Yes/No Yes/No
Read and fully understood the following work instructions and Guidance? <ul style="list-style-type: none"> <li>• Lifejacket and buoyancy aid including servicing bulletins</li> <li>• Marine benthic invertebrate sampling and processing</li> <li>Intertidal soft sediment work</li> </ul>	Yes/No Yes/No Yes/No
Completed the following H & S training? <ul style="list-style-type: none"> <li>• Manual Handling</li> <li>• Water Safety or Sea survival</li> </ul>	Yes/No Yes/No
Previously carried out sample collection under supervision (note how many)?	Yes/No
Clear regarding the aims and requirements of the survey?	Yes/No
<b>Arrival at location:</b>	
Staff has fully compliant PPE	Yes/No
Staff have received activity briefing	Yes/No
<b>Sample Collection:</b>	
Do you understand the responsibilities of each staff member? (Who is recording position/salinity/sample no. etc)	Yes/No
When using the sampling equipment, have the guidelines set out in the benthic sample collection guidance been adhered to?	Yes/No
Sample integrity maintained (Discarded where inappropriate)?	Yes/No
Supporting parameters recorded? (Sediment type, anoxic layer, sample vol, digital image, surface features..)	Yes/No
Correct manual handling technique employed	Yes/No
<b>Sample Processing:</b>	
Was sieve processing procedure followed? (Correct manual handling, gentle flow of water, back washing technique, picking of sieve with tweezers)	Yes/No
Sieve cleaned to prevent cross contamination?	Yes/No
<b>Sample Preservation:</b>	
Staff trained in the use of formaldehyde (understanding of formaldehyde H & S, strength of preservative to be used, buffered, volume required)?	Yes/No
Was the correct protective equipment worn whilst the preservative was being used?	Yes/No
Sample pot clearly labelled with correct information?	Yes/No

Provision for the safe transport of samples in place (for example trailer, separate cab, correct labelling)	Yes/No
Notes:	
Signature: Date:	

## Related documents

---

### Links

- [06\\_10 Generic Risk Assessment Boatwork](#)
  - [10\\_10 Boatwork: instructions for manager](#)
  - [12\\_10 Boatwork: instructions for skippers](#)
  - [725\\_06 Fieldwork](#)
  - [189\\_06 GRA - Grabbing, coring and trawling from Environment Agency vessels](#)
  - [426\\_05 GRA - Working in or near water](#)
  - [193\\_06 GRA - Intertidal soft sediment work](#)
  - [13\\_07 Intertidal soft sediment work](#)
  - [52\\_05 Ecology laboratory safety](#)
  - [368\\_07 SD10 Transport Instruction for formaldehyde](#)
  - [1098\\_08 COSHH for using formaldehyde](#)
  - [1097\\_08 COSHH for preparing and buffering formaldehyde](#)
  - [694\\_06 Safety measures while visiting coastal survey vessels](#)
  - [14\\_10 Selecting, using and maintaining lifejackets and buoyancy aids](#)
  - [010\\_07 Sediment sampling in water for chemical and particle size analyses](#)
  - [Lone working](#)
  - [National Monitoring Procedures Manual](#)
-

## References

- Ankar, S. (1977). Digging profile and penetration of the van Veen grab in different sediment types. *Contributions from the Asko Laboratory*. University of Stockholm, Sweden. No. 16, 22pp.
- Eleftheriou, A., & Holme, N.A. (1984). Macrofauna Techniques. **In:** (eds. N.A. Holme & A.D. McIntyre) *Methods for the Study of Marine Benthos*. 2<sup>nd</sup> edn. pp140-216. Blackwell Scientific, Oxford.
- Entec UK Limited (2005). Assessing the Health and Safety Issues Associated with Fixatives and Preservatives used in Ecological Monitoring and Assessment. Project Report, Environment Agency
- Hartley, J.P., Dicks, B. & Wolff, W.J. (1987). Processing sediment macrofauna samples. **In:** Baker, J.M. & Wolff, W.J. (eds). *Biological surveys of estuaries and coasts*. Cambridge. Cambridge University Press, pp131-139
- ISO/CD. (2001). *Water Quality – Guidelines for quantitative investigations of marine soft-bottom macrofauna – Complementary element*. ISO
- Kingston, P.F. (1988). Limitations on offshore environmental monitoring imposed by seabed sampler design. *Advances in Underwater Technology, Ocean Science and Offshore Engineering*, **16**, 273-281.
- Rumohr, H. (1999). *Soft Bottom Macrofauna: Collection and Treatment of Samples*. Techniques in Marine Environmental Sciences No.27. ICES.
- Smith, P.R.J. (1982). Environmental effects of discharges on the littoral zone of the Humber Estuary. Unpublished Ph.D Thesis. University of Hull.
- Wolff, W.J. (1987). Flora and macrofauna of intertidal sediments. **In:** (eds. J.M. Baker & W.J. Wolff) *Biological Surveys of Estuaries and Coasts*. Estuarine and Brackish Water Sciences Association Handbook. Cambridge University Press, 449pp.
-

## Bibliography

- Bachelet, G. (1990). The choice of sieving mesh size in the quantitative assessment of marine macrobenthos: a necessary compromise between aims and constraints. *Marine Environmental Research*, **30**, 21-35.
- Baker, J.M., & Wolff, W.J., eds. (1987). *Biological Surveys of Estuaries and Coasts*. Estuarine and Brackish Water Sciences Association Handbook. Cambridge University Press, 449pp.
- Barnett, B.E. (1984). Observations on the intertidal fauna of the south bank of the Humber Estuary. *Marine Environmental Research*, **13**, 33-53.
- Barnett, B.E. (1993). National Standard Methodology for Marine Macrofaunal Benthic Sampling. III. Guidelines for Sample Pre-treatment for Marine Benthic Invertebrate Samples. NRA Internal Document.
- Barnett, B.E. (1993). National Standard Methodology for Marine Macrofaunal Benthic Sampling. I. Intertidal Soft Sediments. NRA Internal Document.
- Culling, S. (1992). *National Standard Methodology for Marine Macrofaunal Benthic Sampling. II. Subtidal Soft Sediments*. NRA Internal Document.
- Gray, J.S. (1981). *The Ecology of Marine Sediments*. Cambridge University Press, Cambridge
- Holme, N.A., & McIntyre, A.D., eds. (1984). *Methods for the Study of Marine Benthos*. 2<sup>nd</sup> edn. pp1-26. Blackwell Scientific, Oxford.
- James, R.J., Lincoln-Smith, M.P., & Fairweather, P.G. (1995). Sieve mesh-size and taxonomic resolution needed to describe natural spatial variation of marine macrofauna. *Marine Ecology Progress Series*, **118**, 187-198.
- Kramer, K.J.M., Brockman, U.H., & Warwick, R.E. (1994). *Tidal Estuaries. Manual of Sampling and Analytical Procedures*. A.A. Balkema, Rotterdam, Netherlands.
- McIntyre, A.D., Elliott, J.M., & Ellis, D.V. (1984). Introduction: Design of sampling programmes. In: (eds. N.A. Holme & A.D. McIntyre) *Methods for the Study of Marine Benthos*. 2<sup>nd</sup> edn. pp1-26. Blackwell Scientific, Oxford.
- NPMMG (1999). *UK National Marine Monitoring Programme Green Book*.
- NRA (1993). *Standard Methodologies. Assessment of Estuarine/Marine Water Quality Using Benthic Macroinvertebrates*. National Rivers Authority, Anglian Region.
- OSPAR (1997). *JAMP Eutrophication Monitoring Guidelines: Benthos*. Oslo and Paris Commissions Joint Assessment and Monitoring Programme (9/6/97).
- Pearson, T.H., & Rosenberg, R. (1978). Macrobenthic succession in relation to organic enrichment and pollution of the marine environment. *Oceanography and Marine Biology Annual Review*, **16**, 229-311.
- Rees, H.L., Moore, D.C., Pearson, T.H., Elliott, M., Service, M., Pomfret, J., & Johnson, D. (1990). *Procedures for the Monitoring of Marine Benthic Communities at UK Sewage Sludge Disposal Sites*. Scottish Fisheries Information Pamphlet No.18. DAFS, 79pp.
- Rumohr, H. (1990). *Soft Bottom Macrofauna: Collection and Treatment of Samples*. Techniques in Marine Environmental Sciences No.8. ICES, 18pp.
-